

PURPOSE

The purpose of this chapter is to provide a design standard and a level of quality for the systems and materials to be incorporated into new buildings for the Career-Technical Facilities Assistance Program which are not addressed within the Design Manual.

SYSTEMS

Only those major building systems which differ from or are in addition to those stated within the original Design Manual will be listed in this chapter.

In this Career-Technical Section to the Design Manual, no attempt has been made to recommend or describe the means and methods of assembling the various systems.

MATERIALS

With purpose, the materials mentioned in this chapter are generic. No brand or manufacturer's names are stated. Materials other than those mentioned in this chapter, which meet or exceed the characteristics or performance of the stated materials, will be considered, provided adequate information is submitted for approval by the Design Professional and the Ohio School Facilities Commission. Alternate materials which exceed the cost of materials indicated in the Career-Technical Section of Opinion of Probable Cost in Chapter 1 will be at the school district's cost.

DESIGN CODES AND STANDARDS

It is recommended that all school spaces used primarily by children shall be designed in accordance with the proposed new ADA regulations for children ages 3 through 12. Areas used primarily by students 13 and over and by adults are to be designed in accordance with current ADA regulations. All buildings should adhere to all current codes and standards. Efforts in design should be made to reduce energy consumption to at least 30% below international energy conservation code 2000.

DESIGN FOR SAFETY / SECURITY

Design Professionals and educators are encouraged to embrace the concept known as Crime Prevention Through Environmental Design (CPTED). CPTED encourages planners to include safety elements into a building design at the earliest stages. Examples are administration control at main entrances, avoiding corridors with too many hidden spots, and fewer entrances.

ENERGY USAGE

All systems shall be designed in compliance with ASHRAE STANDARD 90.1 "Energy Standard for Building Except Low-Rise Residential Buildings", and the energy usage requirements prescribed by the Ohio Building Code and the Department of Energy.

THIS PAGE HAS BEEN INTENTIONALLY LEFT BLANK.

A. APPLICATION

1. Used at high bay labs only (Programs 5-7).
2. Locate 8'-0" above finished floor and higher.
Provide masonry below metal panels.

B. COMPONENTS

1. Exterior Finish
 - a. 24 gauge stucco embossed G-90 galvanized steel with high performance finish
2. Core
 - a. Foamed in-place urethane insulation.
3. Interior Finish
 - a. 24 gauge white stucco embossed G-90 galvanized steel.

C. PERFORMANCE

1. Features
 - a. Impact resistant
 - b. Moisture resistant
 - c. Thermal resistant

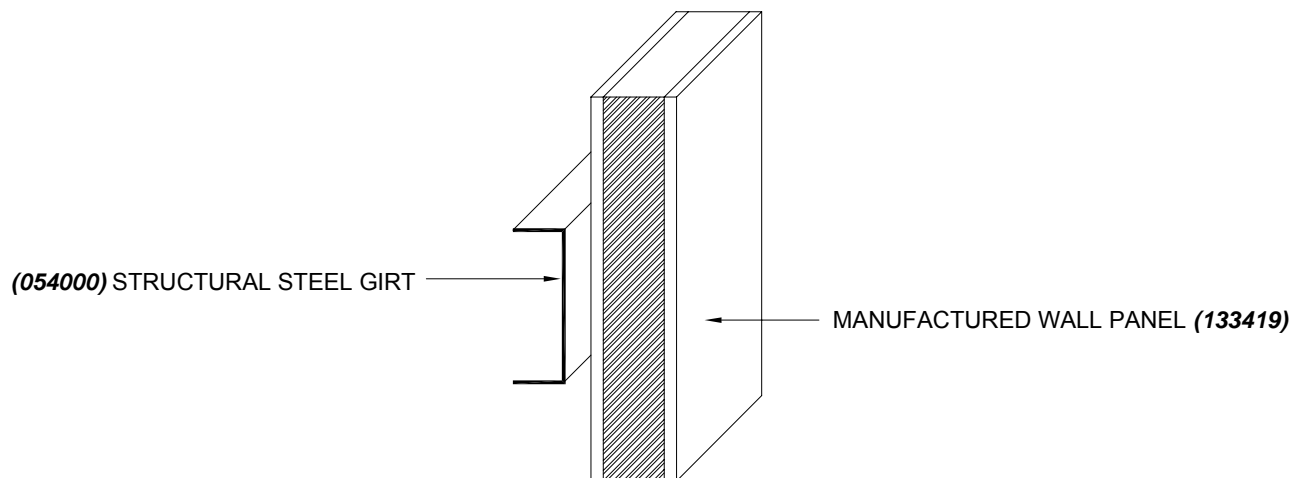

Manufactured Wall Panel
Figure A-1

THIS PAGE HAS BEEN INTENTIONALLY LEFT BLANK.

A. APPLICATION

1. Steep Roofing

B. COMPONENTS

1. Roof Membrane
 - a. Metal roof
2. Roof Insulation
 - a. Batt/blanket insulation
3. Vapor Retarder
 - a. Where required. Refer to Chapter 9.
4. Structural Support
 - a. Roof purlins
5. Slope
 - a. Minimum .25:12

C. PERFORMANCE

1. Features
 - a. Impact resistant
 - b. Moisture resistant
 - c. Thermal resistant

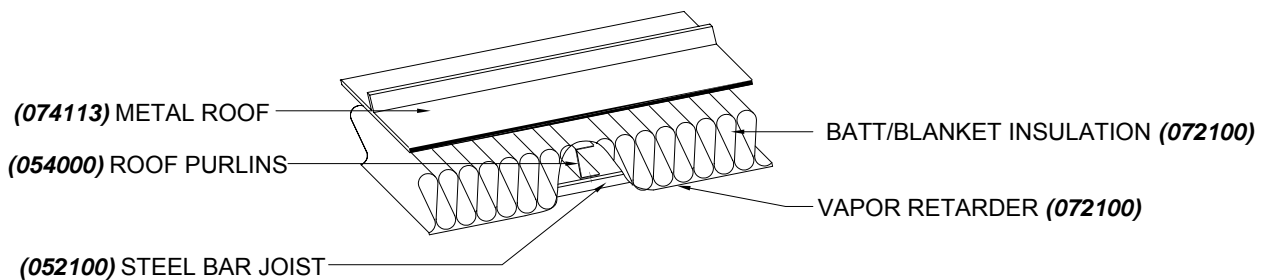

Metal Roof with Batt Insulation
Figure A-1

THIS PAGE HAS BEEN INTENTIONALLY LEFT BLANK.

1.07 PLUMBING FIXTURES/PLUMBING SPECIALTIES (Add the following)

- L. Floor drains shall be installed in each large group restroom, locker room, mechanical room, kitchen area, and high - bay labs. Provide a sediment bucket in the floor drain if conditions exist where solids may enter the drain. Provide **an exterior** oil interceptor at drains if conditions exist where oil, gasoline, etc. may enter the drain.
- P. Install a cold water hose bibb in each large group restroom, locker room and mechanical room. The hose bibb shall be **recessed** behind a lockable door in restrooms and locker rooms, with access by a removable key handle. All high - bay labs shall receive keyed hose bibbs.
- W. Provide trench drains on interior side of all overhead doors located within high - bay labs. Provide a sediment bucket in the drain if conditions exist where solids may enter the drain. Provide **an exterior** oil interceptor at drains if conditions exist where oil, gasoline, etc. may enter the drain.

THIS PAGE HAS BEEN INTENTIONALLY LEFT BLANK

SECTION 1.05: AIR FLOW RATES FOR BUILDING SPACES (Add the following)

<u>SPACE</u>	<u>SUPPLY AIR</u>	<u>EXHAUST AIR</u>
14. Professional Labs (Program Types 1-4)	6 air changes/hour	N/A
15. High Bay Labs (Program Types 5-7)	6 air changes/hour	0.5 cfm/SF

* See program summaries in Chapter 6 for additional HVAC requirements.

THIS PAGE HAS BEEN INTENTIONALLY LEFT BLANK

1.02 LIGHTING (Add the following)

- B. High volume space such as student dining, high - bay labs, etc. shall be illuminated with high-efficiency, high-intensity discharge lamp type light fixtures. Quartz restrike options shall be incorporated into some fixtures to provide an average of 2 footcandles of illumination during the cool-down/warm-up (restrike) period caused by momentary electrical outages.

SCHOOL LIGHTING LEVELS (add the following)

Room Type Classification	1993 IES	Recommended Minimum Footcandles
Professional Labs (program types 1-4)	-	50
High Bay Labs (program types 5-7)	-	60